

液晶模组规格书

LCM Specification

Ⓟ 初定规格 Preliminary specification

Ⓞ 正式规格 Official specifications

项目编号 Project No.	TFT-H035A3HVI ST4R50
产品描述 Product Description	TFT LCD Module 320 x 3RGB x 480 Dots 3.5 " TFT LCD



客户确认签章:

Signature by customer:

Ⓞ 小批量试产 Trial production Ⓞ 大批量生产 Mass production

鑫洪泰科技（广东）有限公司

深圳市鑫洪泰电子科技有限公司

广东省深圳市龙岗区龙岗天安数码城 3 栋 B 座 1202-G

广东省东莞市凤岗镇东深公路 208 号天安数码城 N3 栋 3 楼

文档修订记录 Document revision history :

版本 Version	日期 DATE	修改说明 Modify description	编制 PREPARED BY
11	2021-12-07	初次编制	Li u. YL

一、基本特征 General Feature:

项目 Item	标准值 Standard Value	单位 Unit
显示尺寸 Display Size	3.5"	-
分辨率 Number of Pixels	320(H)x3(RGB)*480(V)	-
显示区域 Active Area	48.96(H) * 73.44(V)	mm
外形尺寸 Outline Dimension	54.76(H) * 83.58(V) * 3.70(D) <TFT+RTP>	mm
观看方向 Viewing Direction	全视角 FULL 0'clock	-
TFT 端口 TFT Interface	兼容接口, 由 IM[0-2] 决定	-
TFT 驱动芯片 TFT Driver IC	ST7796S	-
TFT 驱动电压 TFT Driver Condition	VCI=2.8V, IOVCC=1.8V(Typ)	V
背光 Backlight	白色 LED/6 颗/串联 White LED/6 PCS/Series	-
触摸屏 Touch Panel	** 不带触摸屏 p 带电阻触摸屏 ** 带电容触摸屏 Whitout TP Whit RTP Whit CTP	-
电容触摸屏驱动芯片 CTP Driver IC	- - -	-
电容触摸屏驱动电压 CTP Driver Condition	VDD=3.3V(Typ)	V
TFT 液晶工作温度 Operation Temperature	-20 ~ 70	°C
TFT 液晶储存温度 Storage Temperature	-30 ~ 80	°C

二、外形尺寸 Outline Dimensions

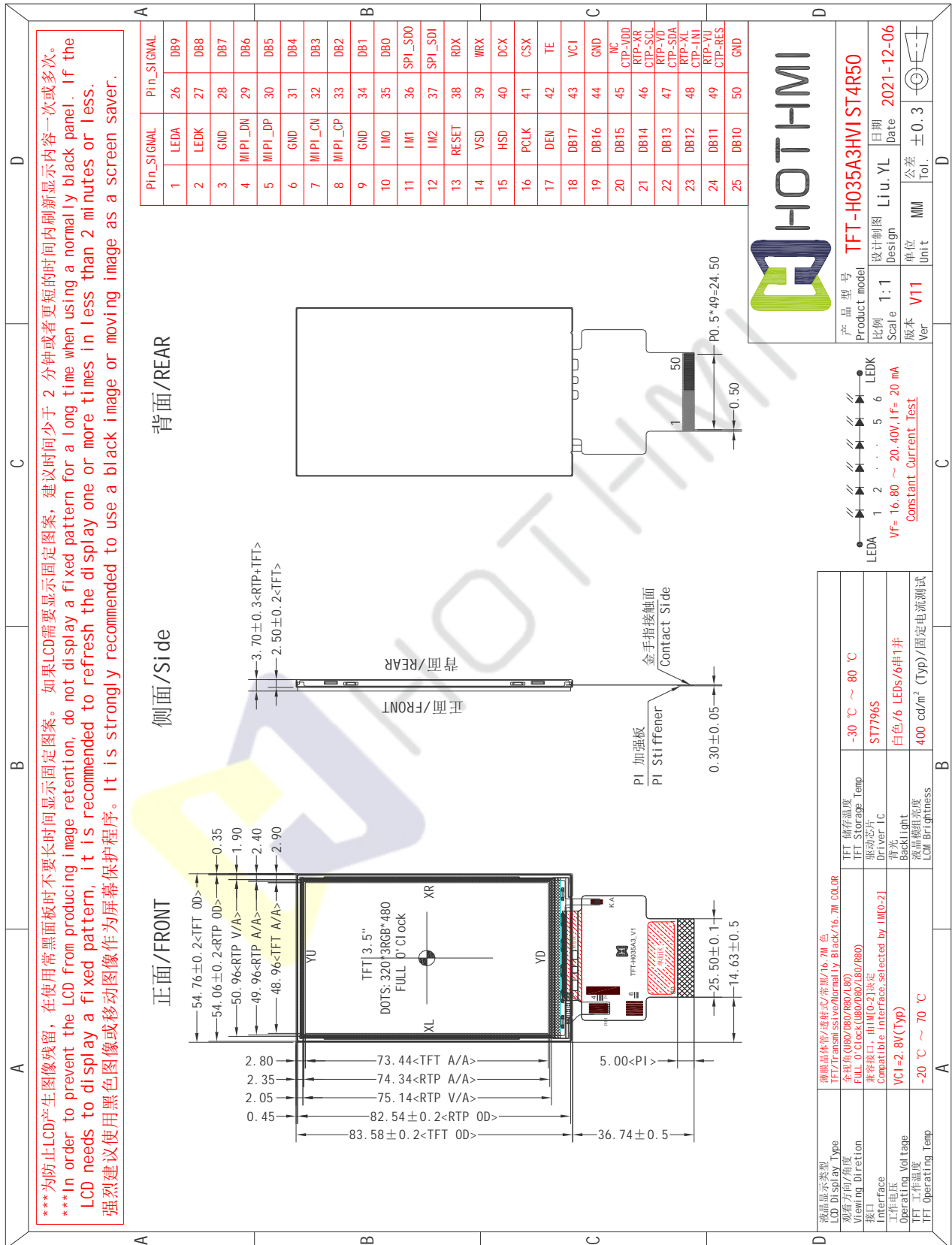

2.Outline Dimensions

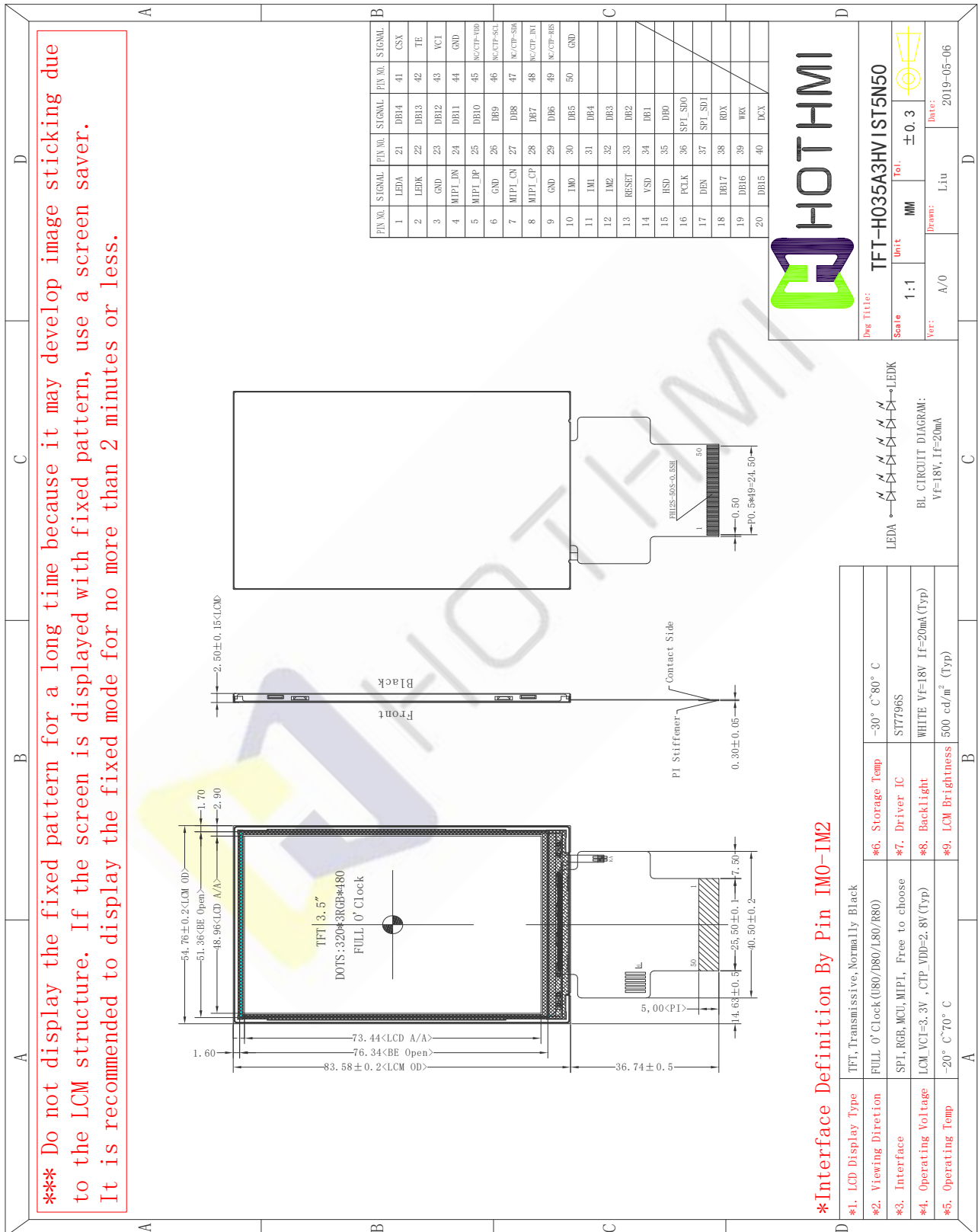

三、引脚说明 Pin Description

3.1. 模组引脚说明 TFT Pin Description

引脚编号 Pin NO.	标号 Symbol	详细描述 Description
1	LEDA	LED Anode
2	LEDK	LED Cathode
1	LED_A	LED Anode
2	LED_K	LED Cathode
3	GND	Ground
4	MIPI_DN	◆ Low voltage differential data signal
5	MIPI_DP	◆ Leave the pin to open when not in use.
6	GND	Ground
7	MIPI_CN	◆ Low voltage differential clock signal
8	MIPI_CP	◆ Leave the pin to open when not in use.
9	GND	Ground
10~12	IM[0~2]	The MCU interface mode select
13	RESET	TFT Reset Pin. Signal is active low.
14	VSD	◆ Vertical synchronizing input signal for RGB interface. ◆ If not used, please fix this pin at GND.
15	HSD	◆ Horizontal synchronizing input signal for RGB interface. ◆ If not used, please fix this pin at GND.
16	PCLK	◆ Dot clock signal for RGB interface. ◆ If not used, please fix this pin at GND.
17	DEN	◆ Data enable signal for RGB interface. ◆ If not used, please fix this pin at GND.
18~35	DB[17~0]	Data Bus. If not used, please fix this pin at GND.
36	SPI_SDO	◆ SPI interface output pin. If not used, let this pin open. ◆ The data is outputted on the falling edge.
37	SPI_SDI	◆ SPI interface input/output pin. ◆ The data is latched on the rising edge. ◆ If not used, please fix this pin at GND.
38	RDX	◆ Read enable in 8080 MCU parallel IF. Low-active. ◆ If not used, please fix this pin at GND.
39	WRX SPI_SCL	◆ Write enable in MCU parallel interface ◆ In SPI mode, this pin is used as SCL. ◆ If not used, please fix this pin at GND.

引脚编号 Pin NO.	标号 Symbol	详细描述 Description
40	DCX	<ul style="list-style-type: none"> ◆ Display data/command selection pin in parallel IF. ◆ If not used, please fix this pin at GND.
41	CSX/SPI_CS	<ul style="list-style-type: none"> ◆ Chip select input pin ("Low" enable). ◆ If not used, please fix this pin at GND.
42	TE	<ul style="list-style-type: none"> ◆ Tearing effect signal is used to synchronize MCU to frame memory writing. ◆ If not used, please let this pin open.
43	VCI	Digital Power
44	GND	Ground
45	NC/CTP_VDD	<ul style="list-style-type: none"> ◆ Power supply input for CTP. ◆ If not used, please let this pin open.
46	RTP-XR CTP-SCL	<ul style="list-style-type: none"> ◆ CTP Serial clock signal. ◆ RTP XR control signal ◆ If not used, please let this pin open.
47	RTP-YD CTP-SDA	<ul style="list-style-type: none"> ◆ CTP Serial data input signal. ◆ RTP YD control signal ◆ If not used, please let this pin open.
48	RTP-XL CTP-INT	<ul style="list-style-type: none"> ◆ CTP_External interrupt to the host. ◆ RTP XL control signal ◆ If not used, please let this pin open.
49	RTP-YU CTP-RES	<ul style="list-style-type: none"> ◆ CTP Reset Pin. ◆ RTP YU control signal ◆ If not used, please let this pin open.
50	GND	Ground
- END -		

3.2. 接线说明 Wiring instructions

MCU 8080 8-bit I/F

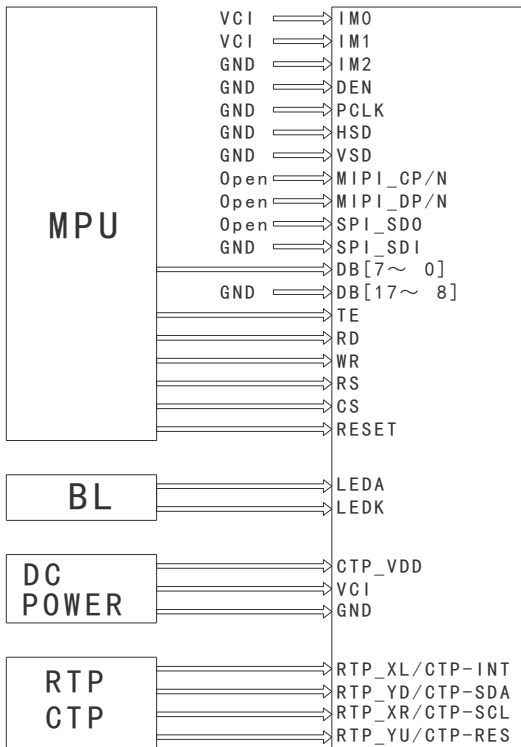

MCU 8080 16-bit I/F

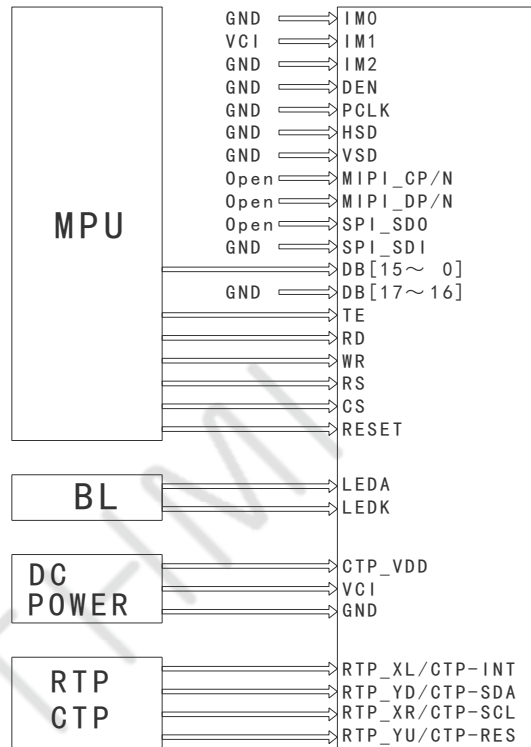

3Line SPI

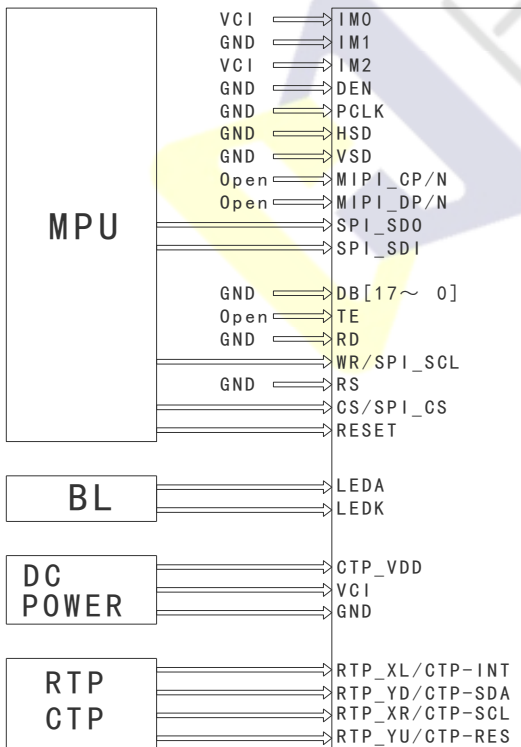

4Line SPI

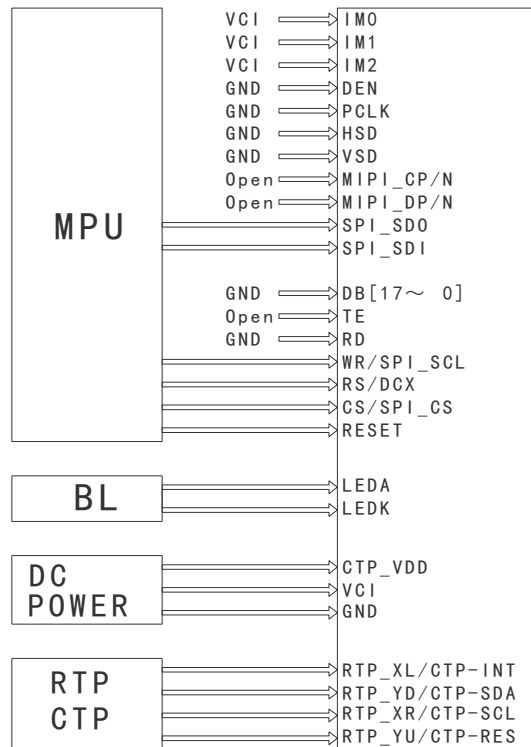

3Line SPI+RGB 16 I/F

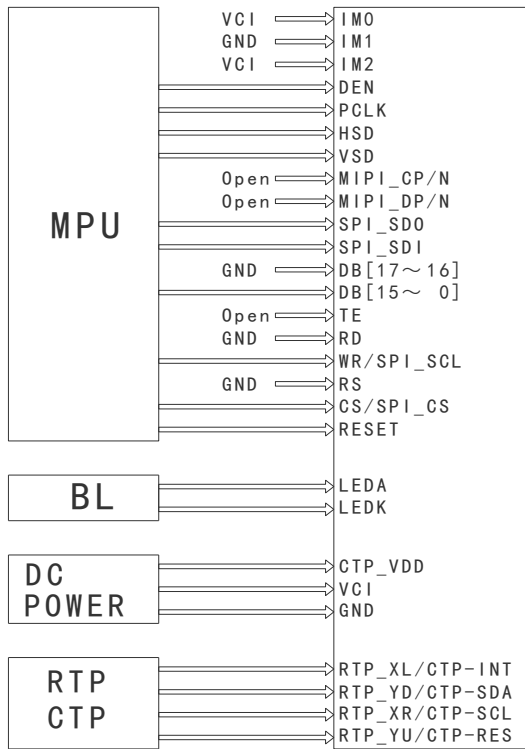

3Line SPI+RGB 18 I/F

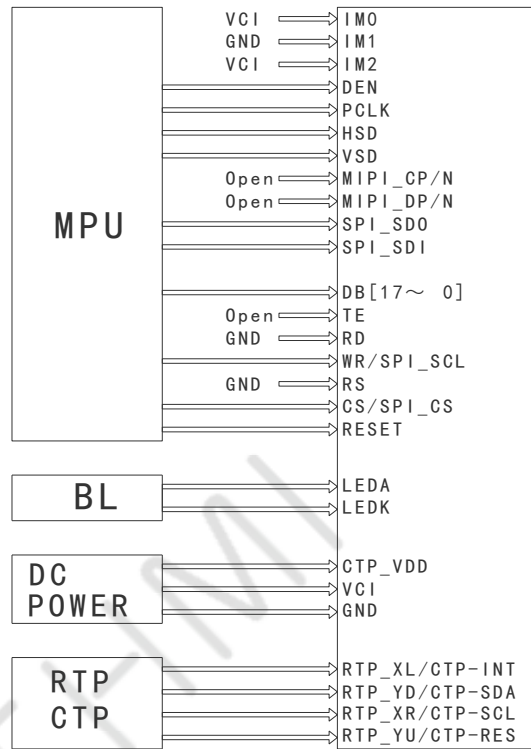

MIPI I/F

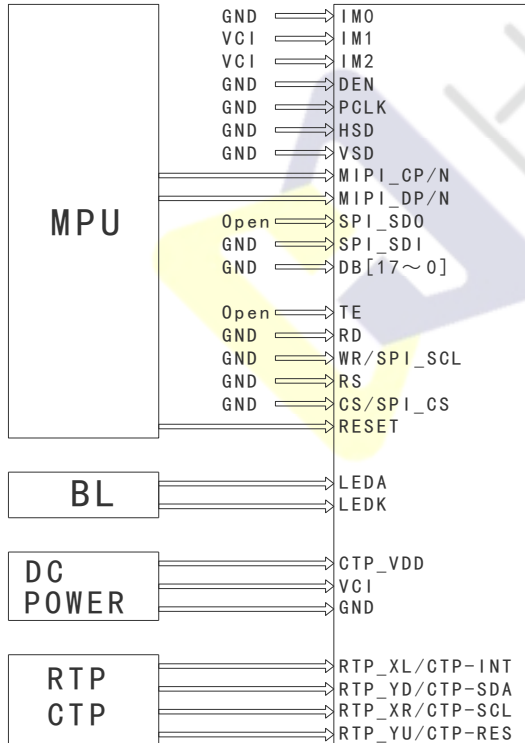

四、电气特性 Electrical Characteristics

4.1. TFT 模组工作条件 TFT LCD Module Operating Conditions

项目 Item	标号 Symbol	条件 Condition	最小值 Min	典型值 Type	最大值 Max	单位 Unit
数字电源 Digital Power	VCI	-	2.6	2.8	3.3	V
I/O 电源 I/O Power	IOVCC	-	1.7	1.8	3.3	V
TFT 栅极导通电压 TFT Gate on voltage	VGH	-	-	-	-	V
TFT 栅极关断电压 TFT Gate off voltage	VGL	-	-	-	-	V
TFT 共模电压 TFT Common Voltage	VCOM	-	-	-	-	V

4.2. 背光工作条件 LED back light specification

项目 Item	标号 Symbol	条件 Condition	最小值 Min	典型值 Type	最大值 Max	单位 Unit
工作电压 Forward voltage	VF	If=20mA /1-chip	16.8	18.0	20.4	V
工作电流 Forward current	IF		-	20	-	mA
亮度 (带 LCD) Luminance (With LCD)	Lv	If=20mA	-	400	-	cd/m ²
LED 寿命 LED life time	Hr	Ta=25±3 °C	50,000	-	-	Hour

注释 Note:

1. LED 寿命 (Hr) 定义为在 Ta=25±3 °C, 上表所示的典型电压电流值条件下持续工作直至亮度低于 50% 的时间。LED life time (Hr) can be defined as the time in which it continues to operate under the condition: Ta=25±3 °C, typical IL value indicated in the above table until the brightness becomes less than 50%.

4.3. 电容触摸屏推荐工作条件 CTP Recommended Operating Conditions

项目 Item	标号 Symbol	条件 Condition	最小值 Min	典型值 Type	最大值 Max	单位 Unit
数字电源 Digital Power	VDD	-	-	-	-	V
I/O 电源 I/O Power	IOVDD	-	-	-	-	V
工作温度 Operation Temperature	T _{OP}	≤90%RH	-20	-	70	°C
储存温度 Storage Temperature	T _{ST}	≤90%RH	-30	-	80	°C

五、液晶光学规格 TFT OPTICAL SPECIFICATION

5.1 概述 Overview

光学规格的测试应在暗室（环境亮度 1lux，温度=25 ±2℃）中使用亮度计系统（测角仪系统和TOPCON BM-5）设备进行测量，测试单元应位于大约在 θ 和 Φ 等于 0 的视角下，距 LCD 表面 50cm 的距离。显示面上测量点的中心应保持固定。测量前背光应工作 30 分钟。

The test of Optical specifications shall be measured in a dark room (ambient luminance 1lux and temperature = 25 ±2℃) with the equipment of Luminance meter system (Goniometer system and TOPCON BM-5) and test unit shall be located at an approximate distance 50cm from the LCD surface at a viewing angle of θ and Φ equal to 0. The center of the measuring spot on the Display surface shall stay fixed. The backlight should be operating for 30 minutes prior to measurement.

5.2 光学规格 Optical Specifications

参数 Parameter		标号 Symbol	条件 Condition	最小值 Min.	典型值 Typ.	最大值 Max.	单位 Unit	备注 Remark
视角范围 Viewing Angle Range	水平 Horizontal	⊙左/L	CR>10	-	80	-	Deg.	Note 1
		⊙右/R		-	80	-	Deg.	
	垂直 Vertical	⊙上/U		-	80	-	Deg.	
		⊙下/D		-	80	-	Deg.	
对比度 Contrast ratio		CR	⊙ = 0°	-	700	-	-	Note2
色域 Color Gamut		CG	CIE1931	-	-	-	%	
白色色度 White Chromaticity		Wx	⊙ = 0°	-0.03	0.309	+0.03	-	Note4 (Based on C Light)
		Wy			0.332			
色彩还原 Reproduct ion of color	红 Red	Rx			0.660			
		Ry			0.325			
	绿 Green	Gx			0.277			
		Gy			0.568			
	蓝 Blue	Bx			0.145			
By	0.072							
响应时间（上升 + 下降） Response Time (Rising + Falling)		Tr+Tf	⊙ = 0° Ta= 25℃	-	30	40	ms	Note5

注释 Note:

1. 视角是对比度大于10的角度。视角确定为相对于光轴的水平或3、9点钟方向和垂直或6、12点钟方向垂直于 LCD 表面（见图 1）。

Viewing angle is the angle at which the contrast ratio is greater than 10. The viewing angles are determined for the horizontal or 3, 9 o' clock direction and the vertical or 6, 12 o' clock direction with respect to the optical axis which is normal to the LCD surface (see FIGURE 1).

2. 对比度测量应在 $\theta = 0$ 的视角和 LCD 表面的中心进行。亮度测量时，视场中的所有像素首先设置为白色，然后设置为暗（黑色）状态。（参见图 1）亮度对比度（CR）是通过数学定义的。

Contrast measurements shall be made at viewing angle of $\theta = 0$ and at the center of the LCD surface. Luminance shall be measured with all pixels in the view field set first to white, then to the dark (black) state. (see FIGUR 1) Luminance Contrast Ratio (CR) is defined mathematically.

$$CR = \frac{\text{Lumiance when displaying a white raster}}{\text{Lumiance when displaying a black raster}}$$

3. 透射率是没有 APF 和没有 CG 的值。

Transmittance is the Value without APF and without CG.

4. 上表中规定的色度坐标应由所有像素首先测量的光谱数据计算为红色、绿色、蓝色和白色。测量应在面板的中心进行。

The color chromaticity coordinates specified in the above table shall be calculated from the spectral data measured with all pixels first in red, green, blue and white. Measurements shall be made at the center of the panel.

5. 电光响应时间测量应如图 2 所示，通过打开和关闭“数据”输入信号来进行。亮度从 10%变化到90%所需的时间是 T_r ，90%到10%是 T_f 。

The electro-optical response time measurements shall be made as FIGURE 2 by switching the “data” input signal ON and OFF. The times needed for the luminance to change from 10% to 90% is T_r , and 90% to 10% is T_f .

Figure1 Measurement Set Up



图 1



图 2

六、TFT 时序特性 TFT Timing Characteristics

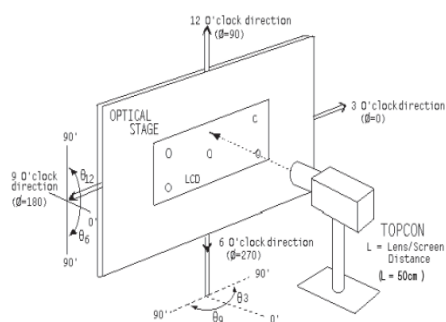
6.1. 并行接口时序特性 / Parallel interface Timing Characteristics (IC SPEC P51-P52)

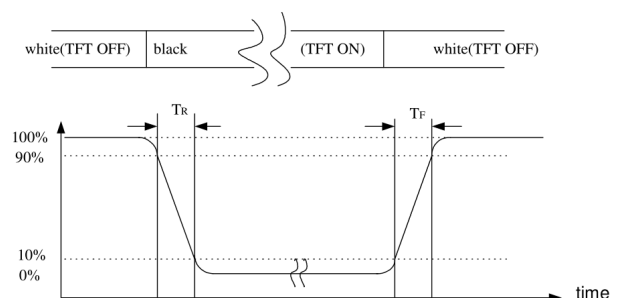
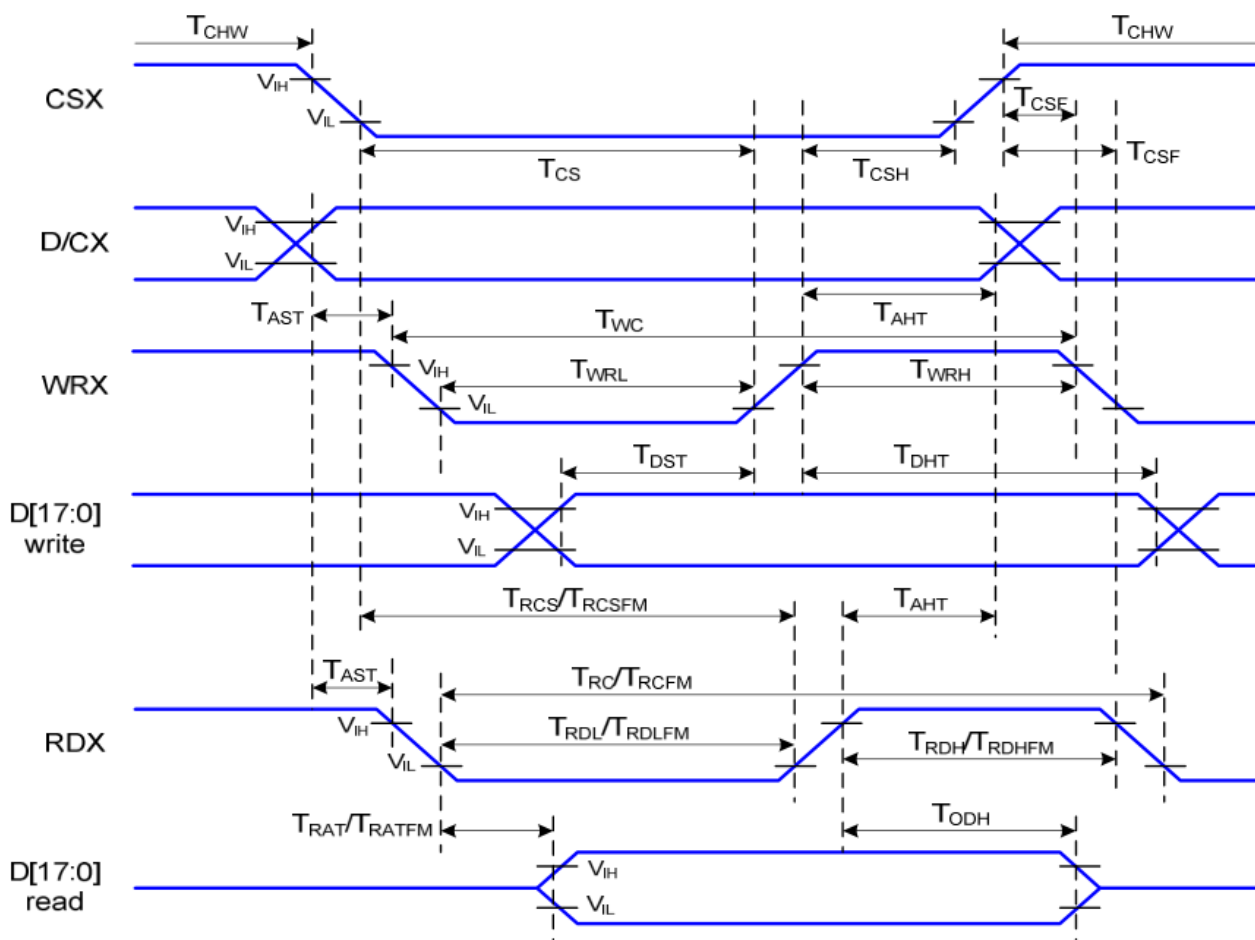

Signal	Symbol	Parameter	Min	Max	Unit	Description
D/CX	T_{AST}	Address setup time	0		ns	-
	T_{AHT}	Address hold time (Write/Read)	10		ns	
CSX	T_{CHW}	Chip select "H" pulse width	0		ns	-
	T_{CS}	Chip select setup time (Write)	15		ns	
	T_{RCS}	Chip select setup time (Read ID)	45		ns	
	T_{RCSFM}	Chip select setup time (Read FM)	355		ns	
	T_{CSF}	Chip select wait time (Write/Read)	10		ns	
	T_{CSH}	Chip select hold time	10		ns	
WRX	T_{WC}	Write cycle	66		ns	-
	T_{WRH}	Control pulse "H" duration	15		ns	

	T_{WRL}	Control pulse "L" duration	15		ns	
RDX (ID)	T_{RC}	Read cycle (ID)	160		ns	When read ID data
	T_{RDH}	Control pulse "H" duration (ID)	90		ns	
	T_{RDL}	Control pulse "L" duration (ID)	45		ns	
RDX (FM)	T_{RCFM}	Read cycle (FM)	450		ns	When read from frame memory
	T_{RDHFM}	Control pulse "H" duration (FM)	90		ns	
	T_{RDLFM}	Control pulse "L" duration (FM)	355		ns	
D[17:0]	T_{DST}	Data setup time	10		ns	For CL=30pF
	T_{DHT}	Data hold time	10		ns	
	T_{RAT}	Read access time (ID)	-	40	ns	
	T_{RATFM}	Read access time (FM)	-	340	ns	
	T_{ODH}	Output disable time	20	80	ns	

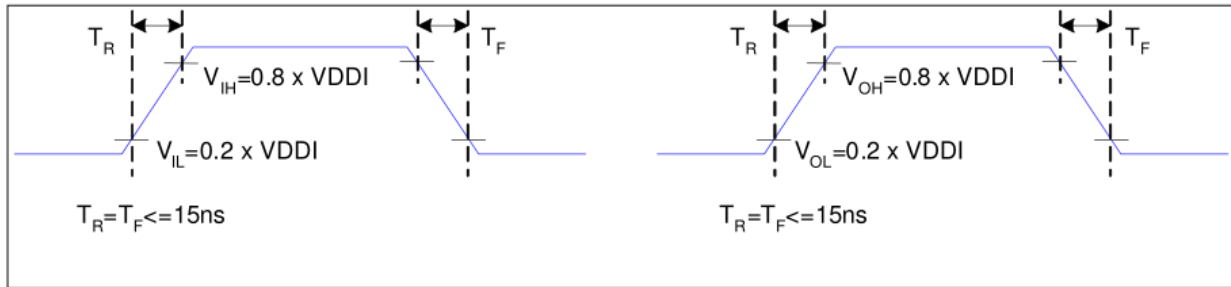

Rising and Falling Timing for I/O Signal

Note: The rising time and falling time (T_r , T_f) of input signal and fall time are specified at 15 ns or less. Logic high and low levels are specified as 20% and 80% of VDDI for Input signals.

6.2.3 SPI 串行接口特性/3 SPI Serial Interface Characteristics(IC SPEC P53)

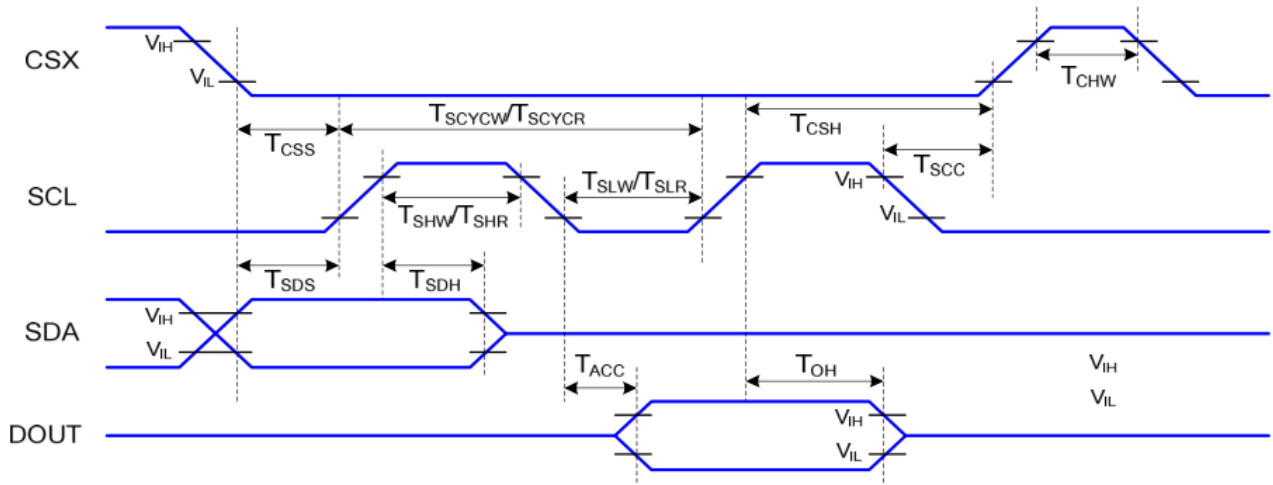
 $V_{DDI}=1.8V, V_{DDA}=2.8V, AGND=DGND=0V, T_a=25\text{ }^{\circ}\text{C}$

Signal	Symbol	Parameter	Min	Max	Unit	Description
CSX	T_{CSS}	Chip select setup time (write)	15		ns	
	T_{CSH}	Chip select hold time (write)	15		ns	
	T_{CSS}	Chip select setup time (read)	60		ns	
	T_{SCC}	Chip select hold time (read)	65		ns	
	T_{CHW}	Chip select "H" pulse width	40		ns	
SCL	T_{SCYCW}	Serial clock cycle (Write)	66		ns	
	T_{SHW}	SCL "H" pulse width (Write)	15		ns	
	T_{SLW}	SCL "L" pulse width (Write)	15		ns	
	T_{SCYCR}	Serial clock cycle (Read)	150		ns	
	T_{SHR}	SCL "H" pulse width (Read)	60		ns	
	T_{SLR}	SCL "L" pulse width (Read)	60		ns	
SDA (DIN)	T_{SDS}	Data setup time	10		ns	
	T_{SDH}	Data hold time	10		ns	
DOUT	T_{ACC}	Access time	10	50	ns	For maximum $CL=30\text{pF}$
	T_{OH}	Output disable time	15	50	ns	For minimum $CL=8\text{pF}$

6.3.4 SPI 串行接口特性/4 SPI Serial Interface Characteristics(IC SPEC P54)

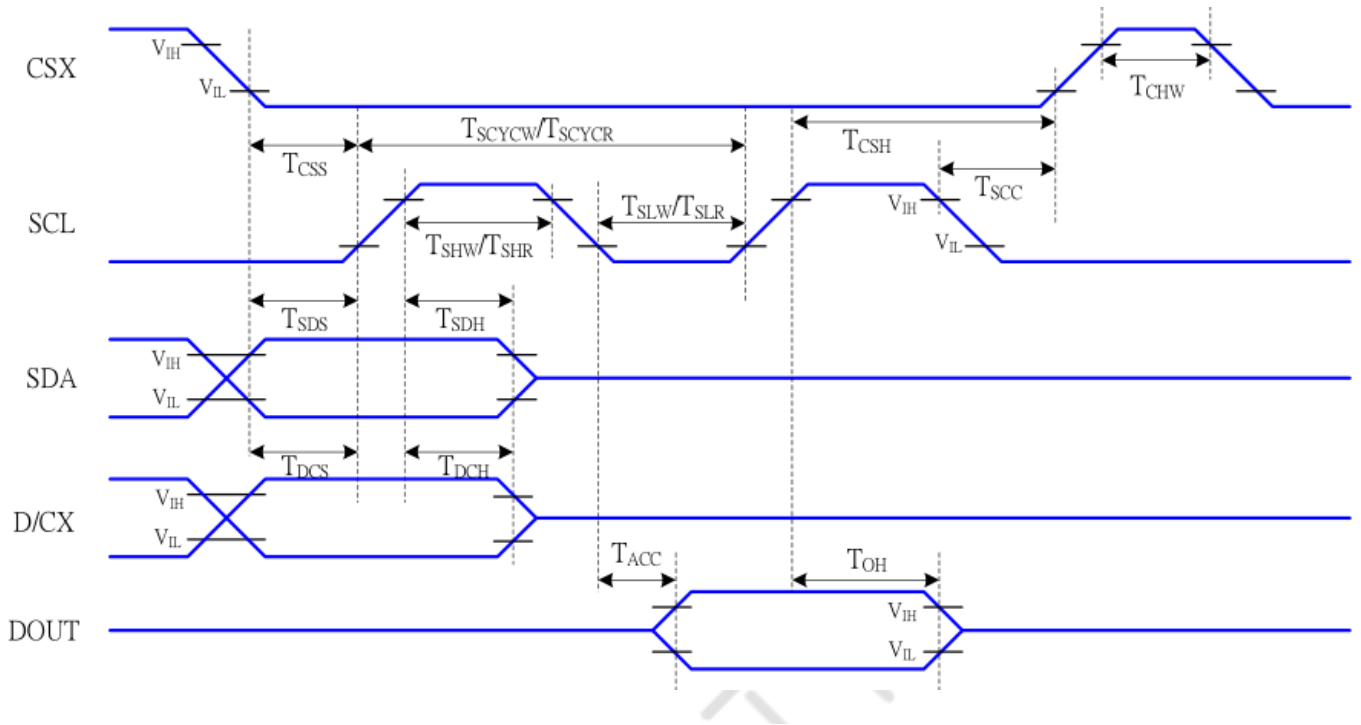

VDDI=1.8V, VDDA=2.8V, AGND=DGND=0V, Ta=25 °C

Signal	Symbol	Parameter	MIN	MAX	Unit	Description
CSX	T_{CSS}	Chip select setup time (write)	15		ns	
	T_{CSH}	Chip select hold time (write)	15		ns	
	T_{CSS}	Chip select setup time (read)	60		ns	
	T_{SCC}	Chip select hold time (read)	65		ns	
	T_{CHW}	Chip select "H" pulse width	40		ns	
SCL	T_{SCYCW}	Serial clock cycle (Write)	66		ns	-write command & data ram
	T_{SHW}	SCL "H" pulse width (Write)	15		ns	
	T_{SLW}	SCL "L" pulse width (Write)	15		ns	
	T_{SCYCR}	Serial clock cycle (Read)	150		ns	-read command & data ram
	T_{SHR}	SCL "H" pulse width (Read)	60		ns	
	T_{SLR}	SCL "L" pulse width (Read)	60		ns	
D/CX	T_{DCS}	D/CX setup time	10		ns	
	T_{DCH}	D/CX hold time	10		ns	
SDA (DIN)	T_{SDS}	Data setup time	10		ns	
	T_{SDH}	Data hold time	10		ns	
DOUT	T_{ACC}	Access time	10	50	ns	For maximum CL=30pF
	T_{OH}	Output disable time	15	50	ns	For minimum CL=8pF

6.4. RGB 接口特性/RGB Interface Characteristics(IC SPEC P55)

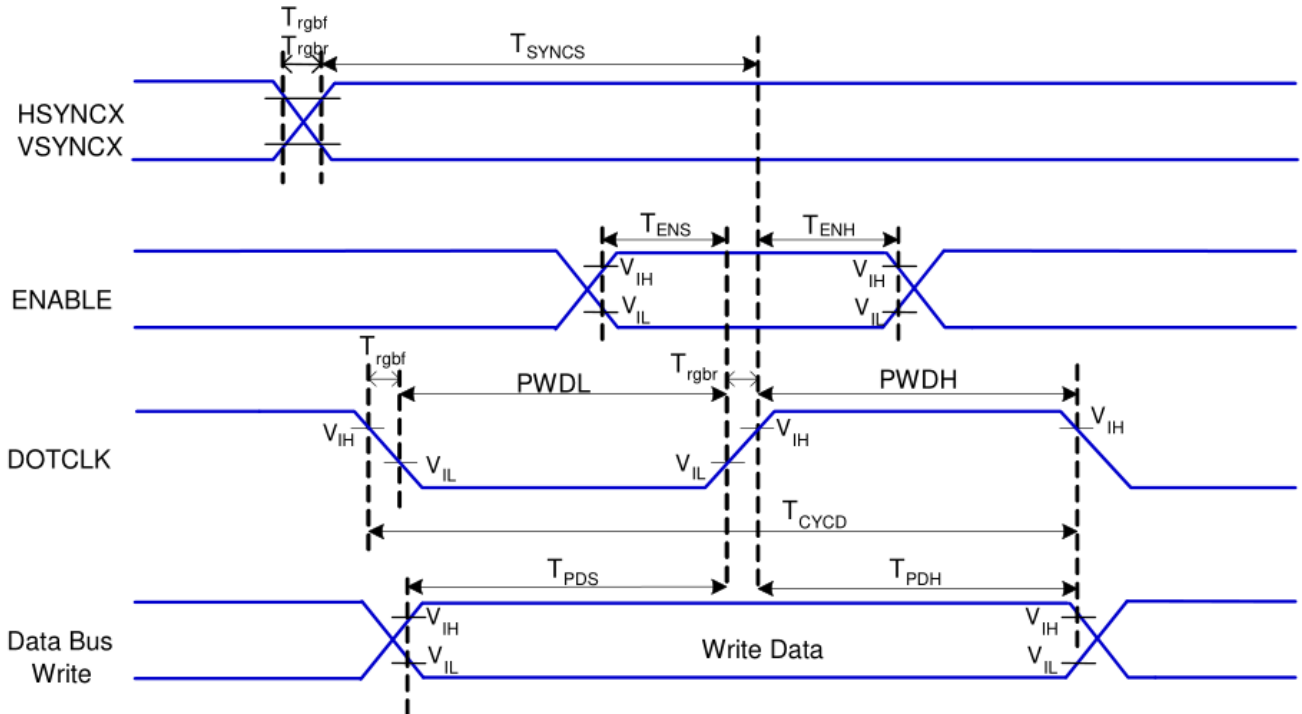

VDDI=1.8V, VDDA=2.8V, AGND=DGND=0V, Ta=25°C

Signal	Symbol	Parameter	MIN	MAX	Unit	Description
HSYNC, VSYNC	T_{SYNCS}	VSUNC, HSYNC Setup Time	15	-	ns	
ENABLE	T_{ENS}	Enable Setup Time	15	-	ns	
	T_{ENH}	Enable Hold Time	15	-	ns	
DOTCLK	PWDH	DOTCLK High-level Pulse Width	30	-	ns	
	PWDL	DOTCLK Low-level Pulse Width	30	-	ns	
	T_{CYCD}	DOTCLK Cycle Time	66	-	ns	
	Trghr, Trghf	DOTCLK Rise/Fall time	-	15	ns	
DB	T_{PDS}	PD Data Setup Time	15	-	ns	
	T_{PDH}	PD Data Hold Time	15	-	ns	

6.5. MIPI 接口特性/MIPI Interface Characteristics(IC SPEC P56-58)

High Speed Mode – Clock Channel Timing

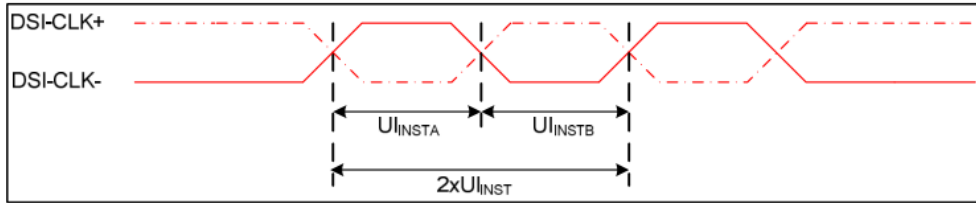

Signal	Symbol	Parameter	MIN	MAX	Unit	Description
DSI-DATA_P/N	2xUI_INST	Double UI instantaneous	4	25	ns	
DSI-DATA_P/N	UI_INSTA ,UI_INSTB	UI instantaneous Half	2	12.5	ns	

High-Speed Data Transmission

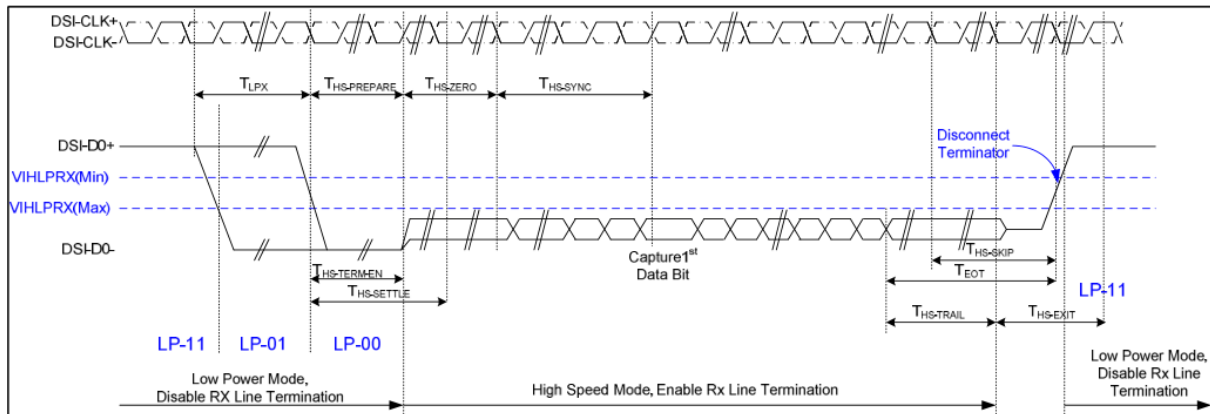

Parameter	Symbol	MIN	TYP	MAX	Unit
Time to drive LP-00 to prepare for HS transmission	$T_{HS-PREPARE}$	40+4UI		85+6UI	ns
Time from start of t HS-TRAIL or t CLK-TRAIL period to start of LP-11 state	T_{EOT}			105+12UI	ns
Time to enable data receiver line termination measured from when Dn crosses VILMAX	$T_{HS-TERM-EN}$			35+4UI	ns
Time to drive flipped differential state after last payload data bit of a HS transmission	$T_{HS-TRAIL}$	60+4UI			ns
Time-out at RX to ignore transition period of EoT	$T_{HS-SKIP}$	40		55+4UI	ns
Time to drive LP-11 after HS burst	$T_{HS-EXIT}$	100			ns
Length of any Low-Power state period	T_{LPX}	50			ns
Sync sequence period	$T_{HS-SYNC}$		8UI		ns
Minimum lead HS-0 drive period before the Sync sequence	$T_{HS-ZERO}$	105+6UI			ns

Switching the Clock Lane between Clock Transmission and Low-Power Mode

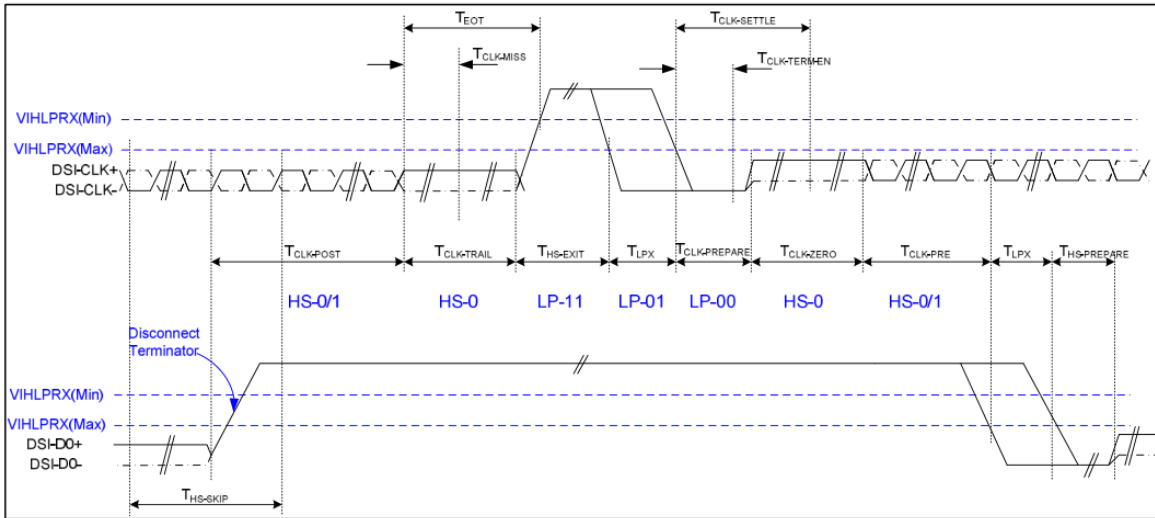

Parameter	Symbol	MIN	TYP	MAX	Unit
Time that the transmitter shall continue sending HS clock after the last associated Data Lane has transitioned to LP mode	$T_{CLK-POST}$	60+52UI			ns
Detection time that the clock has stopped toggling	$T_{CLK-MISS}$			60	ns
Time to drive LP-00 to prepare for HS clock transmission	$T_{CLK-PREPARE}$	38		95	ns
Minimum lead HS-0 drive period before starting Clock	$T_{CLK-PREPARE} + T_{CLK-ZERO}$	300			ns
Time to enable Clock Lane receiver line termination measured from when Dn cross VIL,MAX	$T_{HS-TERM-EN}$			38	ns
Minimum time that the HS clock must be set prior to any associated date lane beginning the transmission from LP to HS mode	$T_{CLK-PRE}$	8			UI
Time to drive HS differential state after last payload clock bit of a HS transmission burst	$T_{CLK-TRAIL}$	60			ns

Bus Turnaround Procedure

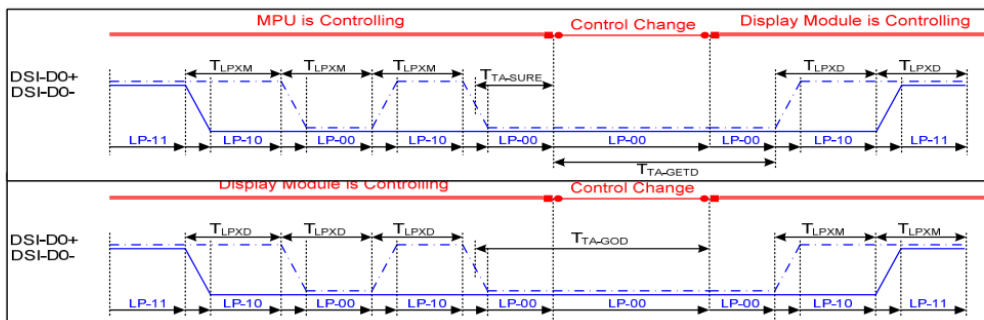

Parameter	Symbol	MIN	TYP	MAX	Unit
Length of any Low-Power state period : Master side	T_{LPX}	50		75	ns
Length of any Low-Power state period : Slave side	T_{LPX}	47.5	50	52.5	ns
Ratio of T_{LPX} (MASTER)/ T_{LPX} (SLAVE) between Master and Slave side	Ratio T_{LPX}	2/3		3/2	
Time-out before new TX side start driving	$T_{TA-SURE}$	T_{LPX}		$2 T_{LPX}$	ns
Time to drive LP-00 by new TX	T_{TA-GET}		$5 T_{LPX}$		ns
Time to drive LP-00 after Turnaround Request	T_{TA-GO}		$4 T_{LPX}$		ns

七、可靠性测试 RELIABILITY TEST

7-1 温度和湿度 Temperature and Humidity

测试项目 TEST ITEMS	条件 CONDITIONS	注释 NOTE
高温储存 High Temperature Storage	Ta=+80°C, 240hrs	
低温储存 Low Temperature Storage	Ta=-30 °C, 240hrs	
高温运行试验 High Temperature Operation	Ta=+70 °C, 240hrs	
低温运行试验 Low Temperature Operation	Ta=-20 °C, 240hrs	
高温高湿（运行测试） High Temperature and High Humidity (Operating)	Ta=+60 °C, 90%RH Max, 240hrs	

注释 Note:

1. 液晶驱动电压。由于液晶材料的特性，该电压随环境温度而变化。Liquid Crystal driving voltage. Due to the characteristics of LC Material, this voltage varies with environmental temperature.

2. 温度和相对湿度范围如下图所示。湿球温度最高应为39°C。并且没有冷凝水。Temperature and relative humidity range are shown in the figure below. Wet bulb temperature should be 39 °C max. and no condensation of water.

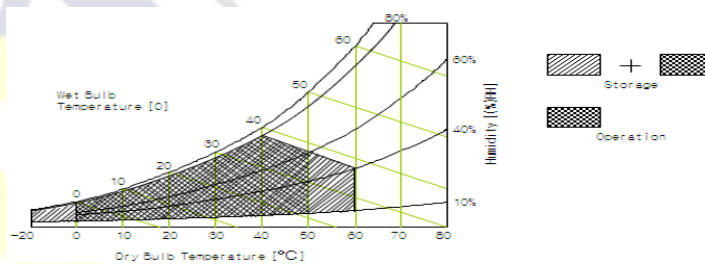

3. 产品经可靠性测试后，仅保证功能正常，无任何致命缺陷（不显示、线路缺陷、显示异常等）。After the reliability test, the product only guarantee function normally without any fatal defect (non-display, line defect, abnormal display etc).

4. 所有显示判断均在面板温度恢复到室温两小时后进行 All display judgments are performed two hours after the panel temperature returns to room temperature

5. Ta: 环境温度 Ambient temperature

7-2 冲击和振动 Shock and Vibration

测试项目 TEST ITEMS	条件 CONDITIONS
包装冲击(非操作) Packing Shock (Non-Operation)	<ul style="list-style-type: none"> ● Shock level: 980m/s² ● Waveform: 1/2 Sine wave, 6msec ● ±X, ±Y ±Z, each axis 1 times
包装振动(非操作) Packing Vibration (Non-Operation)	<ul style="list-style-type: none"> ● Frequency range: 8-33.3HZ ● Stoke: 1.0mm ● Sweep: 10Hz-50Hz ● x, y, z 2 hours for each direction

7-3 静电放电测试 Electrostatic Discharge

测试项目 TEST ITEMS	条件 CONDITIONS
ESD (Non-operation)	150pF, 330Ω, Contact ±2KV, Air : ±4KV. Note 1
	200pF, 0Ω, ±200V Contact test. Note 2

测量点 Measure Point:

1. LCD玻璃和金属边框 LCD glass and metal bezel
2. 连接器引脚 IF connector pins

八、处理和注意事项 HANDLING & CAUTIONS

8-1 操作注意事项 Caution For Operation

◆由于液晶模组是玻璃材质，请勿对其施加强烈的机械冲击或静载荷。请小心搬运，因为冲击、振动和粗心的搬运可能会严重影响产品。如果从高处坠落或受到强烈冲击，玻璃可能碎了。

Since the LCM is made of glass, do not apply strong mechanical impact or static load onto it. Handling with care since shock, vibration, and careless handling may seriously affect the product. If it falls from a high place or receives a strong shock, the glass maybe broken.

◆在规定的电压限制内驱动 LCM 是必不可少的，因为高于限制的电压会导致 LCM 的寿命缩短。由直流引起的电化学反应会导致 LCM 出现不良劣化，因此应避免使用直流驱动。

It is indispensable to drive the LCM within the specified voltage limit since the higher voltage than the limit causes LCM's life shorter. An electro-chemical reaction due to DC causes undesirable deterioration of the LCM so that the use of DC drive should avoid.

◆请勿在电源开启时将 LCM 连接到系统或从系统断开连接。

Do not connect or disconnect the LCM to or from the system when power is on.

◆切勿在高温高湿的异常条件下使用 LCM。

Never use the LCM under abnormal conditions of high temperature and high humidity.

◆当暴露于剧烈的温度波动（热到冷或冷到热）时，LCM可能会受到影响；具体来说，从冷到热的剧烈温度波动会在 LCM 表面产生露水，这可能会影响 LCM 上偏振片的运行。

When expose to drastic fluctuation of temperature(hot to cold or cold to hot), the LCM may be affected; specifically, drastic temperature fluctuation from cold to hot, produces dew on the LCM's surface which may affect the operation of the polarizer on the LCM.

◆在低于工作温度范围的温度下，响应时间将极度延迟，另一方面，在高于其工作范围的温度下，LCM 可能会变黑。然而，这些现象并不意味着 LCM 出现故障或故障。一旦温度恢复到正常运行的推荐温度范围，LCM 将恢复正常运行。

Response time will be extremely delay at lower temperature than the operating temperature range and on the other hand LCM may turn black at temperature above its operational range. However those phenomenon do not mean malfunction or out of order with the LCM. The LCM will revert to normal operation once the temperature returns to the recommended temperature range for normal operation.

◆为防止LCD产生图像残留，在使用常黑面板时不要长时间显示固定图案。如果LCD需要显示固定图案，建议时间少于 2 分钟或者更短的时间内刷新显示内容一次或多次。强烈建议使用黑色图像或移动图像作为屏幕保护程序。

In order to prevent the LCD from producing image retention, do not display a fixed pattern for a long time when using a normally black panel. If the LCD needs to display a fixed pattern, it is recommended to refresh the display one or more times in less

than 2 minutes or less. It is strongly recommended to use a black image or moving image as a screen saver.

8-2 防静电措施 Caution Against Static Charge

◆LCM 使用 C-MOS LSI 驱动器，因此建议客户将任何未使用的输入端连接到 Vdd 或 Vss，上电前不要输入任何信号，并将您的身体、工作/装配区、装配设备接地 防止静电。

The LCM use C-MOS LSI drivers, so customers are recommended that any unused input terminal would be connected to Vdd or Vss, do not input any signals before power is turn on, and ground you body, work/assembly area, assembly equipments to protect against static electricity.

◆缓慢去除保护膜，保持去除方向与面板表面不垂直约 30 度，如有可能，在离子风机等 ESD 控制装置下，工作室湿度应保持在 50%RH 以上，以减少静电风险

Remove the protective film slowly, keeping the removing direction approximate 30-degree not vertical from panel surface, if possible, under ESD control device like ion blower, and the humidity of working room should be kept over 50%RH to reduce the risk of static charge.

◆避免使用合成纤维制成的工作服。我们推荐棉质衣服或其他经过导电处理的纤维。

Avoid the use work clothing made of synthetic fibers. We recommend cotton clothing or other conductivity-treated fibers.

◆在处理 LCM 时，请戴上不带电材料的手套。对地导电手腕和对地导电鞋是必需的

In handling the LCM, wear non-charged material gloves. And the conducting wrist to the earth and the conducting shoes to the earth are necessary

九、初始化代码 LCD display initialization code

```

Void Panel_Initia l_code(void)
{
//TFT分辨率：320 x 480
//接口：3SPI+RGB18
//测试板主控：C8051F340(外购测试板)
//Power: VCI=2.8, IOVCC=1.8
//=====上电复位操作=====//
LCD_RESET=1;
Del ayms(1);          //Del ay 1ms
LCD_RESET=0;
Del ayms(10);        //Del ay 10ms
LCD_RESET=1;
Del ayms(120);       //Del ay 120ms
//=====//
//ST7796S_H035A3-1_SPI+RGB Ini ti al Code
    Del ayms(120);
    SPI_Wri teComm(0x11);
    Del ayms(120);

    SPI_Wri teComm(0x36);
    SPI_Wri teData(0x18);    //48 18 04

    SPI_Wri teComm(0x3A);
    SPI_Wri teData(0x66);    //0x55

    SPI_Wri teComm(0xF0);
    SPI_Wri teData(0xC3);

    SPI_Wri teComm(0xF0);
    SPI_Wri teData(0x96);

    SPI_Wri teComm(0xB4);
    SPI_Wri teData(0x01);

    SPI_Wri teComm(0xB0);
    SPI_Wri teData(0x80);

    SPI_Wri teComm(0xB6);
    
```

SPI_WriteData(0xA0);
SPI_WriteData(0x02);
SPI_WriteData(0x3b);

SPI_WriteComm(0xC1);
SPI_WriteData(0x1D);

SPI_WriteComm(0xC2);
SPI_WriteData(0xA7);

SPI_WriteComm(0xC5);
SPI_WriteData(0x23);

SPI_WriteComm(0xE8);
SPI_WriteData(0x40);
SPI_WriteData(0x8A);
SPI_WriteData(0x00);
SPI_WriteData(0x00);
SPI_WriteData(0x29);
SPI_WriteData(0x19);
SPI_WriteData(0xA5);
SPI_WriteData(0x33);

SPI_WriteComm(0xE0);
SPI_WriteData(0xF0);
SPI_WriteData(0x03);
SPI_WriteData(0x0A);
SPI_WriteData(0x12);
SPI_WriteData(0x15);
SPI_WriteData(0x1D);
SPI_WriteData(0x42);
SPI_WriteData(0x44);
SPI_WriteData(0x50);
SPI_WriteData(0x28);
SPI_WriteData(0x16);
SPI_WriteData(0x15);
SPI_WriteData(0x20);
SPI_WriteData(0x21);

SPI_WriteComm(0xE1);

```
SPI_WriteData(0xF0);  
SPI_WriteData(0x03);  
SPI_WriteData(0x0A);  
SPI_WriteData(0x12);  
SPI_WriteData(0x15);  
SPI_WriteData(0x1C);  
SPI_WriteData(0x42);  
SPI_WriteData(0x44);  
SPI_WriteData(0x52);  
SPI_WriteData(0x28);  
SPI_WriteData(0x16);  
SPI_WriteData(0x15);  
SPI_WriteData(0x20);  
SPI_WriteData(0x23);
```

```
SPI_WriteComm(0xF0);  
SPI_WriteData(0x3C);
```

```
SPI_WriteComm(0xF0);  
SPI_WriteData(0x69);
```

```
SPI_WriteComm(0x21);  
Delays(120);  
SPI_WriteComm(0x29);  
Delays(120);
```

```
}
```

```
Void EnterSLP(void) //EnterSleep_Code
{
SPI_WriteComm((0x28) //Display off
Delays(10);
SPI_WriteComm((0x10); //
Delays(120);
}
Void ExitSLP(void) //ExitSleep_Code
{
SPI_WriteComm((0x11); // Sleep out
Delays(120);
SPI_WriteComm((0x29) //Display on
Delays(120);
}
```

--END--